



Barclays CEO Energy-Power Conference

SEPTEMBER 2023

Disclaimer

Forward-Looking Statements

The statements described herein that are not historical facts are forward-looking statements within the meaning of Section 27A of the Securities Act of 1933, as amended, Section 21E of the Securities Exchange Act of 1934, as amended, and the Private Securities Litigation Reform Act of 1995. These forward-looking statements include, without limitation, statements set forth within this presentation, and other statements regarding future financial performance, revenue and Adjusted Gross Profit guidance for fiscal year 2023, expectation of timing to achieve Adjusted EBITDA breakeven and achieving profitability, anticipated revenue growth and outlook for 2024, anticipated demand for Fluence's energy storage products and services, impact of the Inflation Reduction Act of 2022 or any other proposed legislation, the implementation and anticipated benefits of the Company's enumerated strategic objectives including executing on our transformation, future results of operations, future revenue recognition and estimated revenues, losses, projected costs, prospects, and plans and objectives of management. Such statements can be identified by the fact that they do not relate strictly to historical or current facts. When used in this presentation, words such as "may," "possible," "will," "should," "expects," "plans," "anticipates," "could," "intends," "targets," "projects," "contemplates," "believes," "estimates," "predicts," "potential" or "continue" or the negative of these terms or other similar expressions and variations thereof and similar words and expressions are intended to identify such forward-looking statements, but the absence of these words does not mean that a statement is not forward-looking.

The forward-looking statements contained in this presentation are based on our current expectations and beliefs concerning future developments, as well as a number of assumptions concerning future events, and their potential effects on our business. These forward-looking statements are not guarantees of performance, and there can be no assurance that future developments affecting our business will be those that we have anticipated. These forward-looking statements involve a number of risks, uncertainties (some of which are beyond our control) or other assumptions that may cause actual results or performance to be materially different from those expressed or implied by these forward-looking statements, which include, but are not limited to, our ability to achieve or maintain profitability, our ability to successfully execute our business and growth strategy, including realizing the expected benefits of our partnerships and acquisitions as well as other strategic initiatives we may enter into in the future, our ability to develop new product offerings and services, increased shipping costs and delays in the shipping of our energy storage products, projects delays and site closures and cost-overruns, failure to realize potential benefits of the Inflation Reduction Act of 2022, and other factors set forth under Item 1A. "Risk Factors" in our Annual Report on Form 10-K for the fiscal year ended September 30, 2022, filed with the Securities and Exchange Commission ("SEC") on December 14, 2022, and in other filings we make with the SEC from time to time. New risks and uncertainties emerge from time to time and it is not possible for us to predict all such risk factors, nor can we assess the effect of all such risk factors on our business or the extent to which any factor or combination of factors may cause actual results to differ materially from those contained in any forward-looking statements. Should one or more of these risks or uncertainties materialize, or should any of the assumptions prove incorrect, actual results may vary in material respects from those projected in these forward-looking statements. You are cautioned not to place undue reliance on any forward-looking statements made in this presentation. Each forward-looking statement speaks only as of the date of the particular statement, and we undertake no obligation to publicly update or revise any forward-looking statements to reflect events or circumstances that occur, or which we become aware of, after the date hereof, except as otherwise may be required by law.

Non-GAAP Financial Measures

Included in this presentation are certain non-GAAP financial measures, including Adjusted EBITDA, Adjusted Gross Profit (Loss), Adjusted Gross Profit Margin and Adjusted Net Income (Loss), which are designed to complement the financial information presented in accordance with GAAP because management believes such measures are useful to investors. Non-GAAP financial measures are not a substitute for or superior to measures of financial performance prepared in accordance with GAAP and should be not be considered as an alternative to any other Our non-GAAP metrics have limitations as analytical tools, and you should not consider them in isolation. We believe that such non-GAAP measures, when read in conjunction with our operating results presented under GAAP, can be used to better assess our performance from period to period and relative to performance of other companies in our industry, without regard to financing methods, historical cost basis or capital structure.

See the Appendix to this presentation for a reconciliation of the non-GAAP financial measures to the nearest GAAP measure, which should be carefully evaluated.

A reconciliation of the Company's 2023 Adjusted Gross Profit guidance to the most directly comparable GAAP financial measure cannot be provided without unreasonable efforts and is not provided herein because of the inherent difficulty in forecasting and quantifying certain amounts that are necessary for such reconciliation.

In this presentation, the Company relies on and refers to certain industry and market data and statistics obtained from third-party sources which it believes to be reliable. The Company has not independently verified the accuracy or completeness of any such third-party information. This data is subject to change. In addition, this presentation does not purport to be all-inclusive or to contain all of the information that may be required to make a full analysis of the Company. The recipient should make its own evaluation of the Company and of the relevance and adequacy of the information and should make such other investigations as it deems necessary.





SECTION I

About Us

OUR MISSION

Transform the way we power our world to create a more sustainable future.

PURPOSE-BUILT



PURPOSE-DRIVEN



Best-In-Class Global Energy Storage Solutions Provider

We provide comprehensive energy storage solutions for our customers most complex challenges

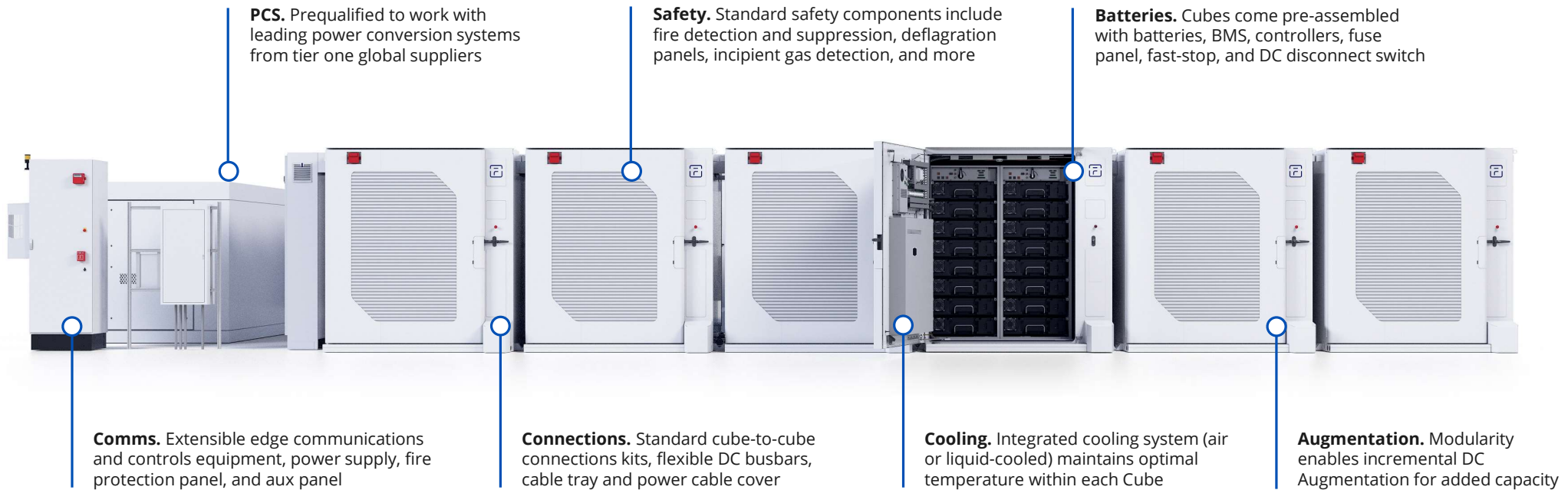

Key Highlights



Utah facility well positioned following passage of IRA



Potential for an additional USA based facility following passage of IRA



Additional facilities being considered around the world



Fluence Contract Manufacturing Locations

Regionalizing our supply chains



A trusted partner for leading companies globally

A broad range of customers across multiple segments

UTILITIES / IPPs



FINANCIALS



C&I





SECTION II

Fluence Offerings

We help customers manage the energy transition through configurable storage solutions, service, and digital application packages

Fluence Energy Storage Solutions & OS

Purpose-built energy storage with integrated hardware & Fluence OS controls software, coupled with engineering, design, & commissioning services options



- Engineering
- Design
- Consultative Services
- Delivery Services

Fluence Long-Term Services

Comprehensive operational services tailored to project needs, including full-wrap capabilities



Operational Services



- 24/7 Monitoring
- O&M Maintenance
- Guarantees, Warranties
- Training
- Capacity Management

Digital Apps for Renewables and Storage

Optimize renewable assets and energy storage with software products and applications that address dispatch, market participation, battery performance, and more

**Mosaic
(Bidding App)**

**Nispera
(APM Platform)**





Fluence's Battery Pack

Gives Fluence greater control over the global supply chain and capitalizes on incentives under the Inflation Reduction Act.

TODAY

Fluence purchases the battery subsystem from OEM suppliers.

2023-2024 OBJECTIVE

Fluence will procure cells competitively and manufacture its own battery pack, which includes a Fluence-made battery module. Initial production start up scheduled for summer 2024.

KEY BENEFITS

- Easier to incorporate new cells and diversify our cell supplier base; creates competition at cell level
- Easier to swap packs in and out of new product variants
- Allows us to incorporate our own BMS technology with more granular data access and system control
- Expands Fluence battery intelligence capabilities





Fluence Battery Pack

Enables easier implementation of integrated solutions while commoditizing battery cells

BATTERY PACK SYSTEM



DCPM

The "brain" of the Pack System, the DCPM collects battery data for communication with Fluence OS and use by cloud-based software, Fluence Mosaic and Fluence Nispera.



Fluence OS



Fluence Mosaic



Fluence Nispera

Battery Cell (280 Ah Standard Size)

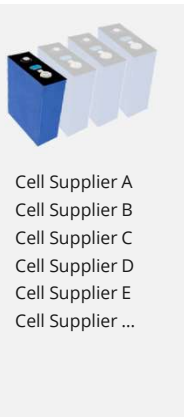

- Cell Supplier A
- Cell Supplier B
- Cell Supplier C
- Cell Supplier D
- Cell Supplier E
- Cell Supplier ...



Battery Module

Manufacturing battery modules in our Utah facility expected to qualify for IRA sec. 45X benefit of \$10 per KWH

Images not to scale





SECTION III

FY 2023 Third Quarter
Financial Highlights

Q3'23 Performance

Clearing Out Majority Legacy Low Margin Contracts; Heading into Q4'23 with expected ~10% Gross Margins¹

Q3'23 Order Intake

\$565M

1.4 GWh Solutions², 0.15 GWh Services,
~1 GW Digital

Q3'23 Revenue Recognized

\$536M

Deployed ~1.5GWh Energy
Storage Solutions³

Long-term Services AUM⁴ at 6/30

2.3 GW

>90% Cumulative Deployed Attachment Rate
as of 6/30/23

Contracted Backlog⁵ at 6/30

\$2.9B

\$2.8B Contracted Backlog at 3/31
\$12.4B Pipeline⁵ as of 6/30

Q3'23 Adjusted Gross Profit Margin⁶

\$24M | 4.4%

Q3'23 GAAP Gross Profit Margin 4.1%
Q3'22 GAAP Gross Profit Margin -2.2%

Digital AUM at 6/30

14.4 GW

3/31 Digital AUM 14.8 GW
Signed ~1 GW of new orders in Q3'23

Note 1: Includes reference to forward-looking Adjusted Gross Profit Margin, a Non-GAAP figure. Refer to above disclaimer on Non-GAAP Financial Measures for a discussion of why we are unable to reconcile forward-looking Adjusted Gross Profit Margin to its most directly comparable GAAP financial measure.

Note 2: Solutions are defined as or have been historically referred to as energy storage products; we believe solutions is more representative of the offering.

Note 3: Calculated in line with revenue recognition basis in \$, based on projects data as of June 30, 2023.

Note 4: Orders attachment rate and Cumulative Deployed attachment rate based on MWh; refer to supplemental metric sheet for definition of attachment rates.

Note 5: Refer to Pipeline definition and Contracted Backlog definition within appendix.

Note 6: Non-GAAP figure. Refer to reconciliation of Adjusted Gross Profit Margin to the most directly comparable GAAP financial measure in our appendix.



PROGRESSING ON STRATEGIC OBJECTIVES

On Track to Meet Our Commitments; Secured US Battery Supply



Deliver profitable growth

- Raising FY'23 guidance range to \$2.0 – 2.1 billion for revenue; \$117-\$132 million for Adjusted Gross Profit¹.
- Reaffirming our belief that we will be close to Adjusted EBITDA breakeven in our fiscal fourth quarter.



Develop products and solutions that our customers need

- Received a 400 MWh award that will utilize Northvolt's NMC batteries, making this our first major project that will use European manufactured batteries.



Convert our supply chain into a competitive advantage

- Signed a U.S. battery cell supply agreement with AESC, under which Fluence will procure U.S. manufactured battery cells, which we believe positions Fluence to be one of the first companies to provide customers with a storage product that qualifies for the 10% ITC bonus for using domestic content under the IRA.



Use Fluence Digital as a competitive differentiator and margin driver

- Launched our predictive maintenance feature for battery energy storage on our Nispera application.



Work better

- Increased total cash² balance by more than \$30 million quarter over quarter closing at \$416 million, further bolstering our liquidity.



Note 1: Non-GAAP figure. Refer to disclaimer on Non-GAAP Financial Measures for a discussion of why we are unable to reconcile Adjusted Gross Profit guidance to its most directly comparable GAAP financial measure.
Note 2: Total cash includes Cash and cash equivalents + Restricted Cash + Short term investments.



Strong Demand and Execution Lead to Increased FY'23 Guidance

>\$1B of pipeline growth quarter over quarter. Reaffirm expected 35-40% revenue growth in FY'24

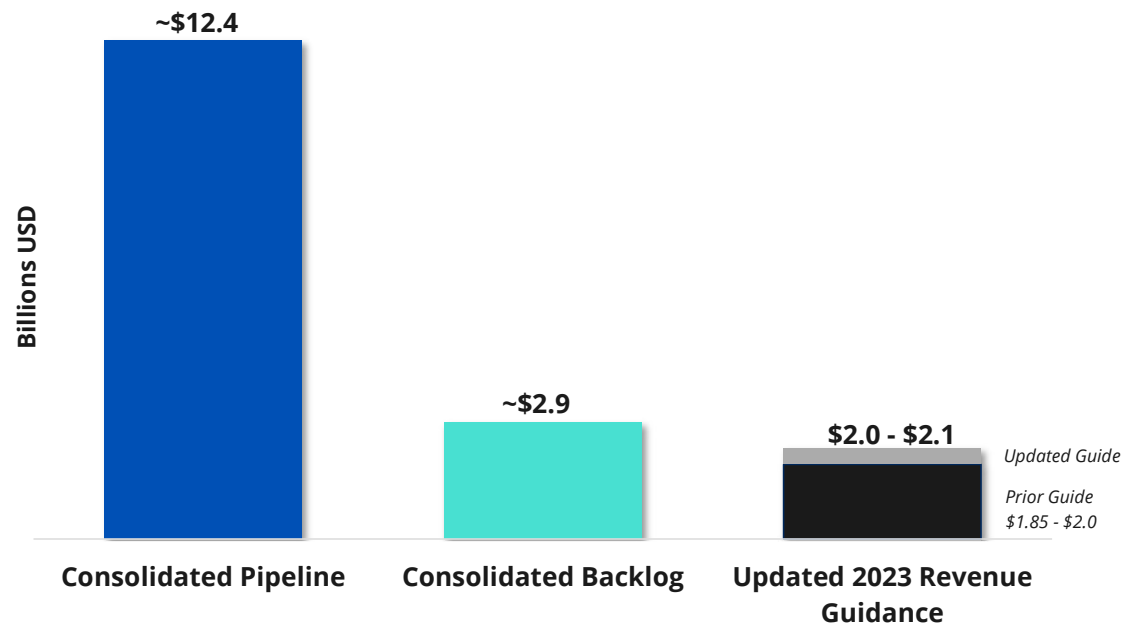

Chart as of June 30, 2023



Note 1: All figures in \$ billion, unless specified.
Note 2: Updated FY2023 Revenue Guidance is based on guidance shown on page 11.

PIPELINE

- The pipeline experienced a significant **increase of ~\$1.2 billion** on a quarter-to-quarter basis, primarily attributed to customers actively assimilating the IRA domestic content regulations that were unveiled in mid-May.

BACKLOG

- Backlog **increased to ~2.9 billion** quarter over quarter as IRA driven customer activity starts to come to fruition.



FLNC the Preferred Supplier of Storage Solutions; Builds Strong Customer Relationships and Drives Long-Term Service Contracts

Customers cite safety, performance, bankability, and supply chain assurance in selecting FLNC; deployed services attachment rate >90%

Safety

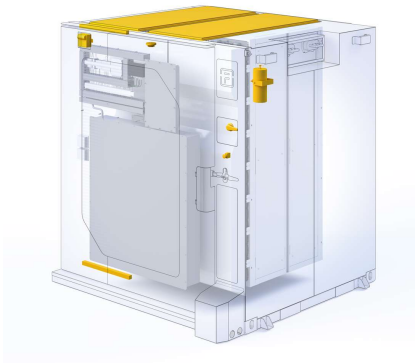

Battery Safety: UL1973, IEC62619, IEC61508
System Safety: UL9540
Fire Protection: NFPA 855
Software: 24/7 monitoring

Performance



Embedded fast response (150ms), advanced controls applications, and grid forming capabilities.

Bankability

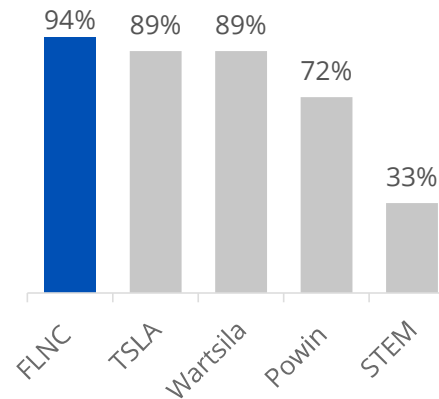

Source: BNEF, Energy Storage System Cost Survey 2022, Figure 32 Storage providers & integrators bankability survey results 2022.

*Note select survey results displayed.

Supply Chain Assurance

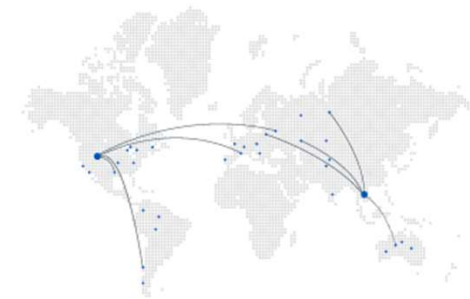

All FY 2023 battery needs are **in country or in transit**, providing high confidence for execution and achieving guidance.





Appendix

Early US Battery Cell Supply Secured

Signed agreement in July with AESC in which FLNC will procure US manufactured battery cells

Multi-year deal with initial shipments expected in **Q4 2024**

Supports FLNC to capture the **\$10/kWh incentive** for manufacturing battery modules under the IRA

Provides FLNC with a **first mover advantage** as it will be one of the first companies to provide customers with an energy storage product that expects to qualify for the 10% ITC bonus for using domestic content under the IRA

IRA Domestic Content Regulations Provide Some Answers, More Clarity Still Needed; Reaffirm Prior IRA Expected Impacts

- Section 45X incentives expected to be a volume driver
- Reaffirm 10-15% gross margins
- To be accounted for as reduction to Cost of Goods and Services
- Expect to elect direct payment for first 5 years of credit



AI-Based Predictive Maintenance For Batteries

Identify, prioritize, and act on storage performance issues to reduce downtime

- AI models are used to detect temperature anomalies that could result in component failure and alert the user before a component fails and causes an outage
- Supports preventative maintenance of storage assets at the component level, from enclosure down to the battery cell level
- Automatic notifications are sent out to select users based on variable deviations from reference behaviors

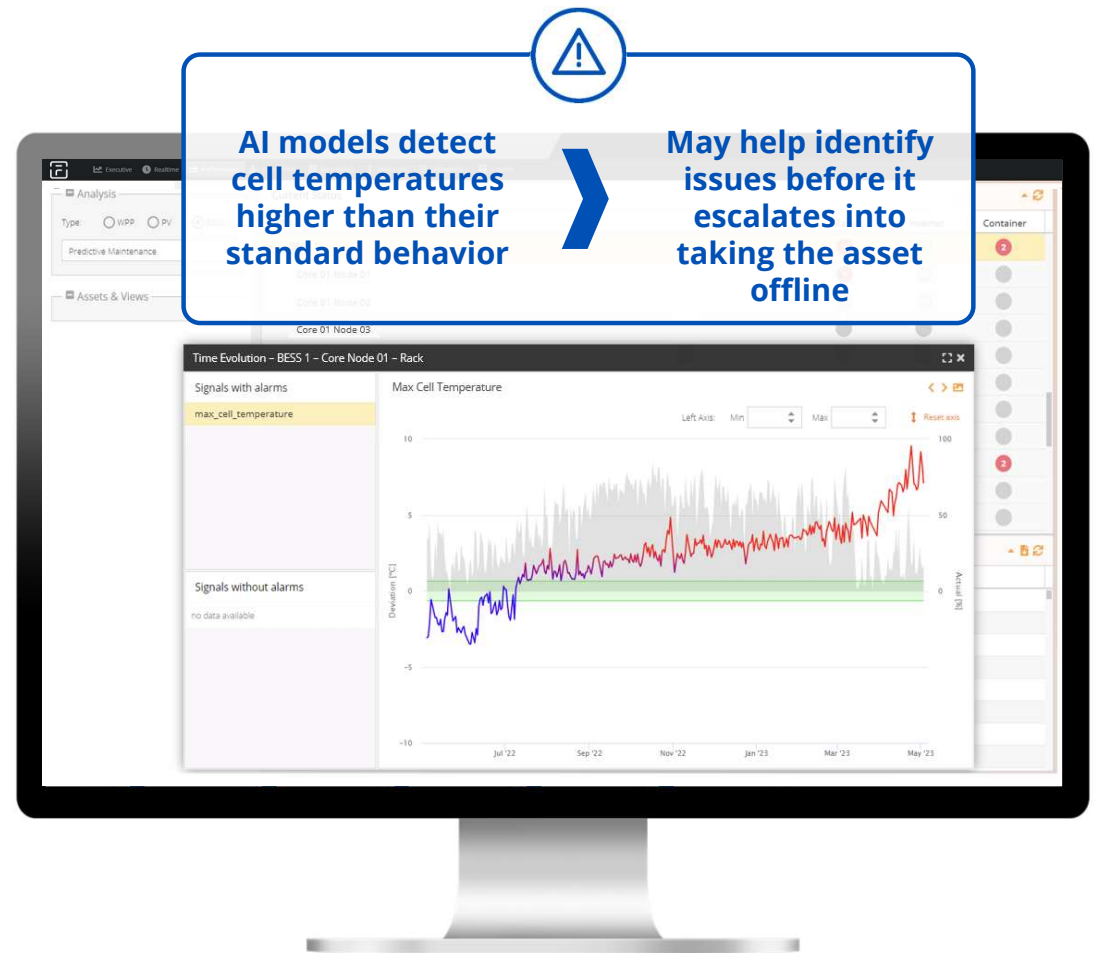

Transforming the way we power our world

2022
SUSTAINABILITY
REPORT



Fluence Publishes Inaugural Sustainability Report

- **Maintaining accountability through transparency**



Diversity, Equity and Inclusion

FY'23 Target: 33% female hires



End of Life Management

Developing Fluence's circular economy framework



Conflict Minerals

Ensure our actions do not contribute to the armed conflicts causing human rights violations



Forced Labor

Commitment letter emphasizing its zero tolerance

Third Quarter 2023 Financial Performance

Strong Topline Performance and Positive Quarterly Cashflow

All figures in \$ million, unless specified ³	Q3'22	Q2'23	Q3'23
Revenue	239	698	536
Adjusted Gross Profit ¹	(3)	32	24
Operating expenses excluding stock comp	(51)	(61)	(54)
Operating expenses, % of Revenue	21.4%	8.8%	10.0%
Adjusted EBITDA ¹	(53)	(27)	(26)
Total Cash ²	762	384	416
GAAP metrics			
Gross Profit	(5)	31	22
Net Income (Loss)	(61)	(37)	(35)



Note 1: Non-GAAP figure. Refer to Appendix for reconciliation of Adjusted Gross Profit, Adjusted Gross Profit Margin, and Adjusted EBITDA to the most directly comparable GAAP financial measures.

Note 2: Total cash includes Cash and cash equivalents + Restricted Cash + Short term investments.

Note 3: May not reconcile to financial statements due to rounding.

HIGHLIGHTS

- 124% YoY revenue growth in Q3'23, select projects ahead of schedule pulling forward revenue recognition.
- Continued execution of legacy backlog that resulted in adjusted gross profit margin¹ of approximately 4.4% up from negative (1.1%) in prior year adjusted gross profit margin¹.
- Q3'23 overhead spend in line with framework, YTD was 10.9% vs prior YTD of 17.2%
- Ended Q3'23 with \$416M of total cash, in line with prior guidance. ~\$165M of undrawn revolver and ~\$80M of supply chain financing facility available.

Raising FY'23 guidance; Expect to be close to Adjusted EBITDA breakeven in Q4 FY'23

Reaffirm 35-40% year over year growth; and positive Adj. EBITDA for FY'24

All figures in \$ million, unless specified

	FY 2022	FY 2023 Prior Guidance	FY 2023 Current Guidance
Revenue	\$1,199	\$1,850 - \$2,000	\$2,000 - \$2,100
Adj. Gross Profit ¹	\$(54)	\$110 - \$135	\$117 - \$132

Note 1: Non-GAAP figure. Refer to appendix for reconciliation of FY 2022 Adjusted Gross Profit (Non-GAAP financial figure) to its most directly comparable GAAP financial measure. Refer to prior disclaimer on Non-GAAP Financial Measures for a discussion of why we are unable to reconcile Adjusted Gross Profit guidance to its most directly comparable GAAP financial measure



1. Implied Q4'23 Guidance for Revenue at ~\$500M and Adj. Gross Profit¹ at >\$50M
 - Narrowed FY'23 guidance range
 - Improved supply chains driving guidance raise
2. Q4'23 expect cash flow breakeven
3. Maintain 35-40% revenue growth outlook for FY'24 on higher FY'23 revenue guide
4. Expected FY'24 revenue split H1 25% / H2 75%
5. Battery supply locked up for FY'24

YTD 2023 Financial Performance

Strong Year Over Year Improvement

All figures in \$ million, unless specified³

	Q3'22 YTD	Q3'23 YTD
Revenue	757	1,545
Adjusted Gross Profit ¹	(66)	69
Operating expenses excluding stock comp	(130)	(169)
Operating expenses, % of Revenue	17.2%	10.9%
Adjusted EBITDA ¹	(193)	(79)
Total Cash ²	\$762	416
GAAP metrics		
Gross Profit	(73)	65
Net Income (Loss)	(233)	(110)



Note 1: Non-GAAP figure. Refer to Appendix for reconciliation of Adjusted Gross Profit, Adjusted Gross Profit Margin, and Adjusted EBITDA to the most directly comparable GAAP financial measures.

Note 2: Total cash includes Cash and cash equivalents + Restricted Cash + Short term investments.

Note 3: May not reconcile to financial statements due to rounding.

HIGHLIGHTS

1. Significant year over year improvement resulting in 104% increase in revenue
2. Continued execution of legacy backlog that resulted in approximately 4.5% YTD adjusted gross margin¹, up from negative (8.8%) in prior YTD.
3. Q3'23 overhead spend in line with framework, YTD 10.9% compared to prior YTD of 17.2%



Fluence Ultrastack™

High performance product built for the complex requirements of transmission segment

GROWTH IN DISTRIBUTED ENERGY RESOURCES

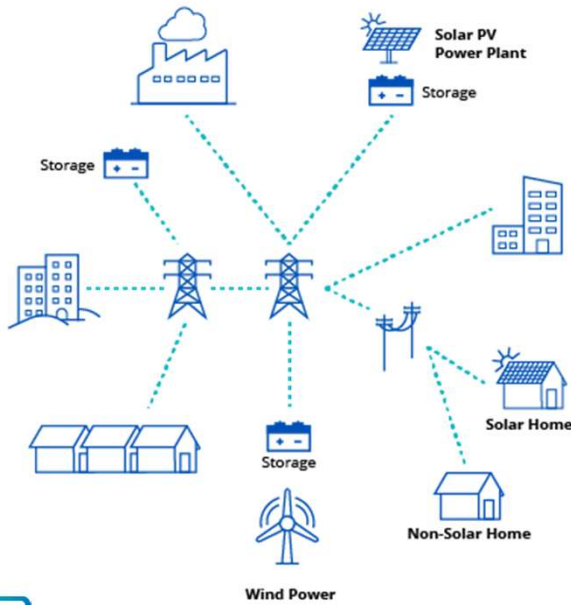

DRIVES DEMAND FOR STORAGE AS TRANSMISSION ASSETS¹

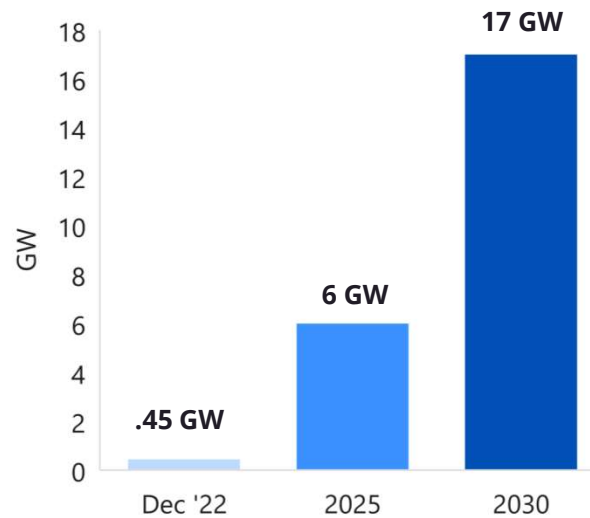

Fluence has been awarded a cumulative 650 MWs for Energy-Storage-as-Transmission, leading the industry

REQUIRING PROPRIETARY, HIGH-PERFORMANCE SOLUTIONS

Ultrastack™ Capabilities



Faster Response Time



Enhanced Cybersecurity



Higher Technical Performance



Advanced Controls Applications



1. Global ISO Market Opportunities, Forecasts by S&P Global

Q3'23 Ending Cash at \$416M, No Recourse Debt, In-line with Prior Commitments

Expect FY'23 to end with liquidity >\$500M; ample liquidity⁴ for cash needs

All figures in \$ million, unless specified

DESCRIPTION	Q3'23A	FY'23 Framework Intact
Total Cash¹ as of 3/31/23	384	
Financing	-	Continue to assume no recourse debt or equity financing
Investing (Capex) ³	\$(8)	Expect Low double digit Use of Cash for Full FY
Adj. EBITDA ⁵	\$(26)	See comments on slide 11
Change in Operating Cash ²	\$66	10% of YOY revenue increase; stronger operating cash in H2
Total Cash as of 6/30/23	\$416	

Note 1: Total cash includes Cash and Cash Equivalents + Restricted Cash + Short-term investments.

Note 2: Change in Operating Cash primarily segregates impacts of Adjusted EBITDA from other elements of Operating Cash. Refer to full disclosure in the Statements of Cash Flows in Annual Report on Form 10-K and our Quarterly Reports on Form 10-Q. Includes impact of cash flow from working capital facilities.

Note 3: Primarily Capex, may not tie to financials due to rounding

Note 4: In addition to revolving credit facility, the Company also has access to a supply chain financing facility.

Note 5: Non-GAAP figure. Refer to reconciliation of Adjusted EBITDA to the most directly comparable GAAP financial measure in our appendix.



Definitions

ITEM	DEFINITION
Pipeline	Represents our uncontracted, potential revenue from energy storage products and solutions, service, and digital software contracts, which have a reasonable likelihood of contract execution within 24 months.
Contracted Backlog	Represent signed purchase orders or contractual minimum purchase commitments with take-or pay provisions. For our energy storage products and solutions contracts, contracted backlog includes signed customer orders or contracts under execution prior to when substantial completion is achieved. For service contracts, contracted backlog includes signed service agreements associated with our storage product projects that have not been completed and the associated service has not started. For digital applications contracts, contracted backlog includes signed agreements where the associated subscription has not started.
Deployed	Represents cumulative energy storage products and solutions that have achieved substantial completion and are not decommissioned.
Assets Under Management	Assets under management for service contracts represents our long-term service contracts with customers associated with our completed energy storage products and solutions. We start providing maintenance, monitoring, or other operational services after the storage product projects are completed. In some cases, services may be commenced for energy storage solutions prior to achievement of substantial completion. Not limited to energy storage solutions delivered by Fluence. Assets under management for digital software represents contracts signed and active (post go live). Assets under management serves as an indicator of expected revenue from our customers and assists management in forecasting our expected financial performance
BESS	Acronym for battery energy storage system
APM	Acronym for asset performance management platform



Note 1: Additional definitions provided in supplemental metric sheet.

Non-GAAP Financial Measures & Reconciliations¹

(\$ in millions)	Q2'22	Q3'22	FY22	Q2'23	Q3'23	YTD Q3'22	YTD Q3'23
GROSS PROFIT (LOSS)	(14.8)	(5.2)	(62.4)	30.8	21.8	(73.1)	64.7
ADD (DEDUCT):							
STOCK-BASED COMPENSATION	0.7	2.6	8.5	1.3	1.2	6.9	3.4
AMORTIZATION	-	-	-	-	0.5	-	0.5
OTHER EXPENSES ^(c)	-	-	-	0.1	0.1	-	0.4
ADJUSTED GROSS PROFIT (LOSS)¹	(14.1)	(2.6)	(53.9)	32.2	23.6	(66.2)	69.0
ADJUSTED GROSS PROFIT (LOSS) PERCENTAGE OF REVENUE	(4.1%)	(1.1%)	(4.5%)	4.6%	4.4%	(8.8%)	4.5%

(\$ in millions)	Q2'22	Q3'22	FY22	Q2'23	Q3'23	YTD Q3'22	YTD Q3'23
NET LOSS	(60.7)	(60.8)	(289.2)	(37.4)	(35.0)	(233.0)	(109.6)
ADD (DEDUCT):							
INTEREST EXPENSE (INCOME), NET ^(a)	0.5	(0.2)	(0.3)	(1.1)	(0.2)	0.9	(2.0)
INCOME TAX EXPENSE (BENEFIT)	0.1	(1.0)	1.4	(0.1)	(1.3)	(0.5)	(2.1)
DEPRECIATION AND AMORTIZATION	1.5	2.0	7.1	2.7	2.7	4.9	7.9
STOCK-BASED COMPENSATION ^(b)	2.7	7.4	44.1	7.3	5.7	35.0	21.4
OTHER EXPENSES ^(c)	-	-	1.6	1.9	1.9	-	5.4
ADJUSTED EBITDA¹	(55.9)	(52.6)	(235.3)	(26.7)	(26.2)	(192.7)	(79.0)

Note 1: May not reconcile to financial statements due to rounding.

(a) Net interest expense (income) for the three months ended June 30, 2023 consists of \$1.5 million of interest expense and \$1.7 million of interest income. Net interest expense (income) for the three months ended June 30, 2022 consists of \$0.6 million of interest expense and \$0.8 million of interest income. Net interest expense (income) for the nine months ended June 30, 2023 consists of \$4.1 million of interest expense and \$6.1 million of interest income. Net interest expense (income) for the nine months ended June 30, 2022 consists of \$1.9 million of interest expense and \$1.1 million of interest income.

(b) Includes incentive awards that will be settled in shares and incentive awards that will be settled in cash.

(c) Amounts for the three and nine months ended June 30, 2023 include costs related to the restructuring plan, including severance. Beginning the three months ended June 30, 2023, costs related to the Covid-19 pandemic and the cargo loss incident are no longer excluded from the Company's non-GAAP results. Historically, the Company excluded these charges. All periods presented have been recast in order to make the non-GAAP financial measure comparable period over period.



Note: For more information on adjustments to non-GAAP financial measures, please refer to the corresponding period's respective investor presentations and earnings releases available on the Fluence Investor Relations website at <https://ir.fluenceenergy.com/> for reconciliations to the most directly comparable GAAP financial measures and related footnotes; provided, that as noted above, costs related to the Covid-19 pandemic and the cargo loss incident are no longer excluded from the Company's non-GAAP results beginning the period ended June 30, 2023 and the periods presented herein have been recast from historical presentation accordingly.



Investor Relations Contact

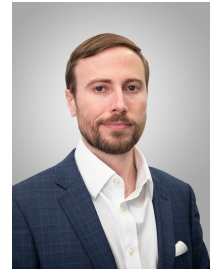

Lexington May

Vice President, Finance & Investor Relations
Lexington.May@fluenceenergy.com